

# Outdoor Central PV Inverter for 1500V System

SPI3125K-B-HUD Series



## Product Features

### High performance

- 3-level technology, max. efficiency up to 99.02%
- Anti-PID function to ensure power generation

### Safety and reliability

- IP55 design, adapt to environment of high temperature, salt, and extreme cold etc.
- Intelligent fan speed control and fault detection for system reliability

### Advanced intelligence

- Intelligent fault recording function for fast analysis
- Intelligent online upgrade function for easy management

### Saved investment

- DC 1500V system, low system cost
- Night SVG function optional
- Modular and compact product design

## Function Diagram

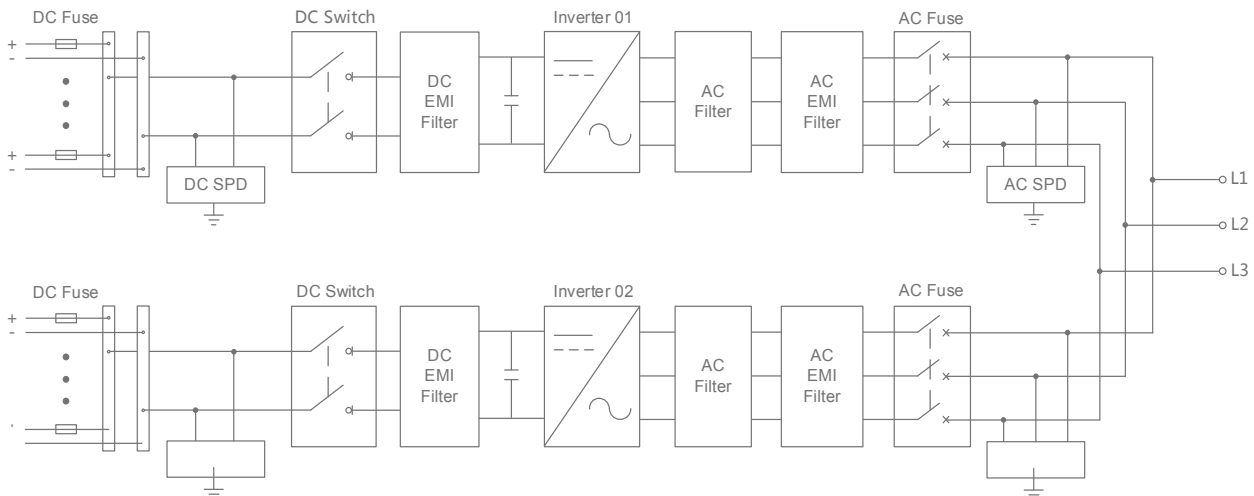

# Technical Specification

| Items                       | SPI3125K-B-HUD  |
|-----------------------------|---|
| <b>DC Input</b>             |   |
| Max. PV input voltage       | 1500Vdc   |
| Max. PV input current       | 4912A   |
| No. of PV input strings     | 16~24 optional  |
| No. of MPPTs                | 2 (1 optional)  |
| MPPT voltage range          | 875~1500Vdc   |
| Starting voltage range      | 915Vdc  |
| MPPT efficiency             | >99.9%  |
| <b>AC Output</b>            |   |
| Rated AC output power       | 3125kW  |
| Max. output power           | 3594kVA@30°C/3437@45°C/3125kVA@50°C   |
| Max. output current         | 3458A   |
| Rated AC output voltage     | 600Vac  |
| Rated grid frequency        | 50Hz/60Hz   |
| Grid frequency range        | 45~55Hz/55~65Hz   |
| Power factor                | >0.99 (at rated power)  |
| PF adjustable range         | 0.8 leading~0.8 lagging   |
| THDi                        | <3% (at rated power)  |
| <b>Efficiency</b>           |   |
| Max. efficiency             | 99.02%  |
| European efficiency         | 98.70%  |
| <b>Protection</b>           |   |
| LVRT function               | Yes   |
| AC side parallel technology | Yes   |
| Fault wave record diagnosis | Yes   |
| Online upgrade              | Yes   |
| Night SVG function          | Optional  |
| Anti-PID function           | Optional  |
| <b>General</b>              |   |
| Dimensions (W×H×D)          | 2150×2260×1190mm  |
| Weight                      | 2700kg  |
| IP grade                    | IP55  |
| Cooling type                | Intelligent forced air cooling  |
| Altitude                    | 5000m (>3000m derating)   |
| Operating temperature range | -35°C~60°C  |
| Relative humidity           | 0~100%  |
| Display                     | LCD   |
| Communication               | Ethernet/RS485  |
| Standard                    | NB/T32004-2018, Q/GDW1617-2015, GB/T37408-2019, CNCA/CTS0002-2014, IEC62109-1, IEC62109-2, EN61000-6-2, EN61000-6-4, IEC61727, IEC62116, IEC60068, IEC60529, IEC61683 |

■ Specifications are subject to change without prior notice.

**Kehua Digital Energy Co., Ltd.**

Add: No. 457, Malong Road, Torch High-Tech Industrial Zone, Xiamen Fujian China  
Tel: +86-592-5160516 Fax: +86-592-5162166 www.kehua.com

