

Installation environment

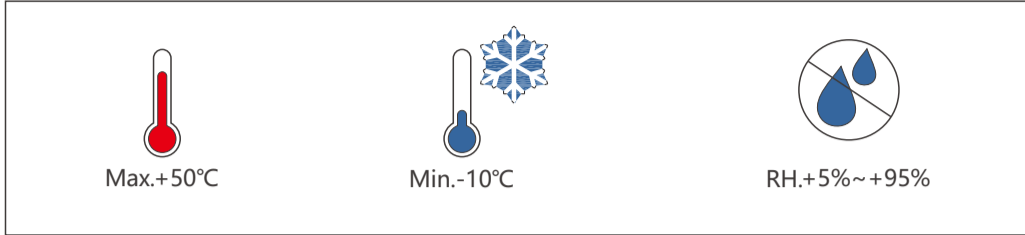

Installation tools

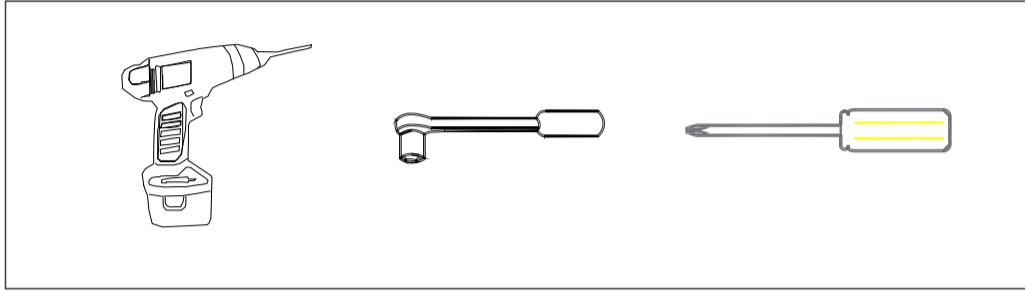

1. Check

1-1 Check Packing List

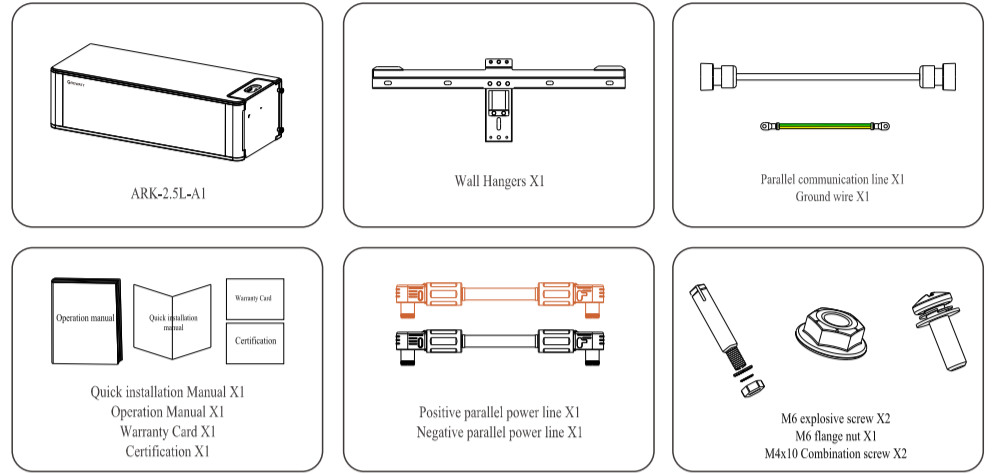

1-2 Check accessories

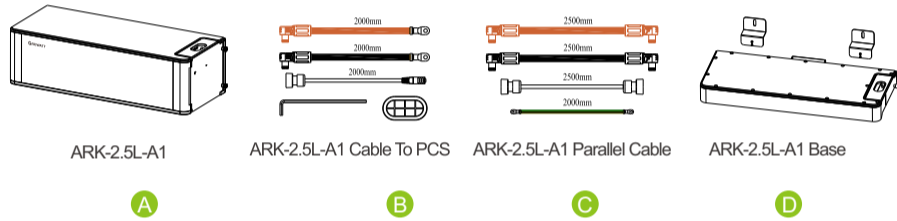

Installation Method	Compound Mode
Standard Wall-Mounted Installation	A+B
Standard floor installation	A+B+D
Wall-Mounted Battery system stacked in two line	A+B+C
Floor installation battery system stacked in two line	A+B+C+D*2

System size

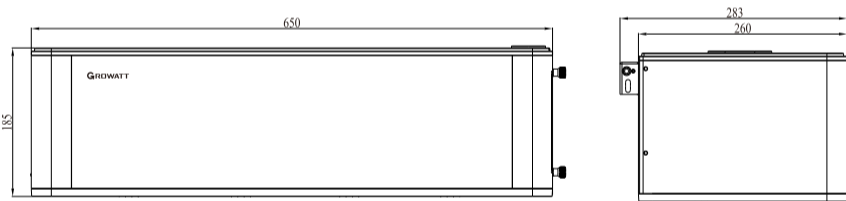

2. Floor installation with base

2-1 Installation Location Requirements

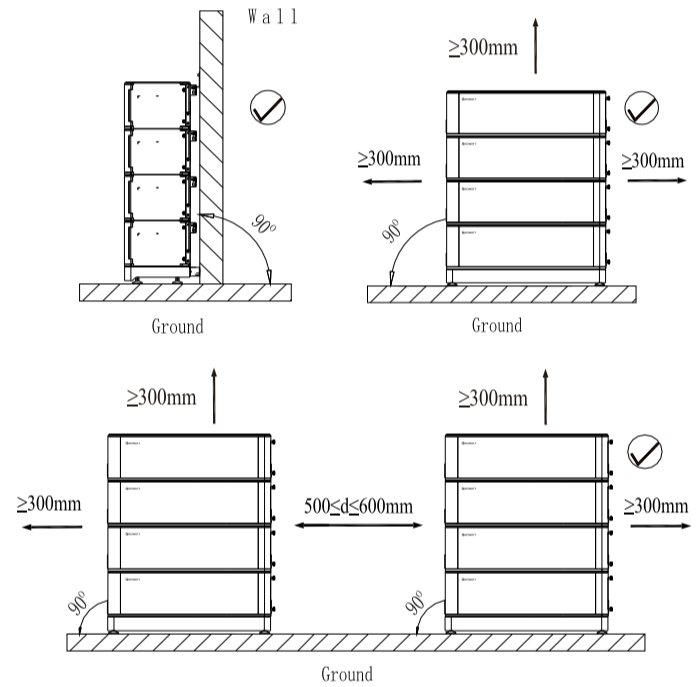

- If more than 4 batteries are used, base mounting is recommended.
- For floor installation with base, the maximum stack number of the battery is ten. But if the battery number is greater than six, we recommend stacking two stacks.

2-2 Installation Procedure

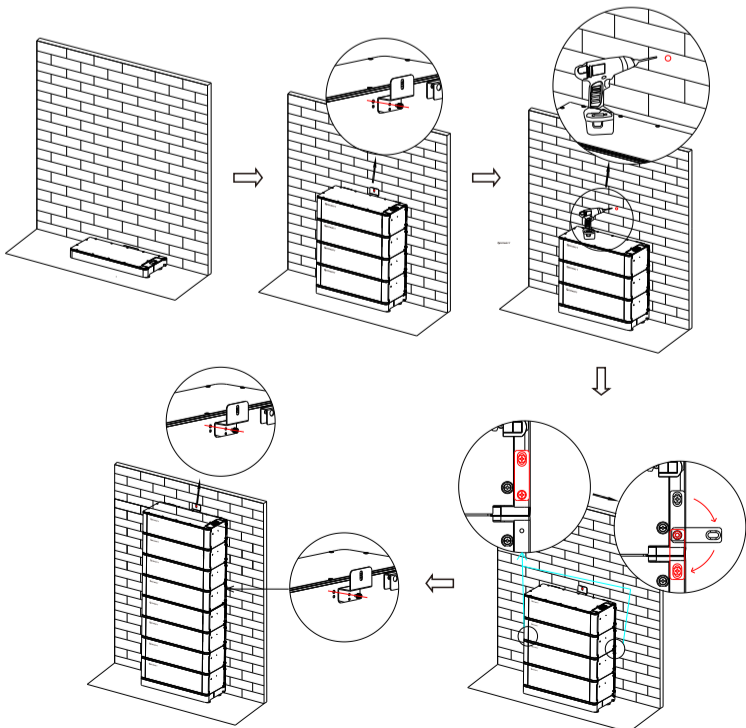

Note: The safety part needs to be installed at the top battery, however, once the number of the battery pack is higher than 7, one more safety part should be installed in the middle battery which is shown the last step. Avoid drilling holes in the water pipes and cables buried in the wall.

3. Wall-Mounted Installation Process

3-1 Installation Location Requirements

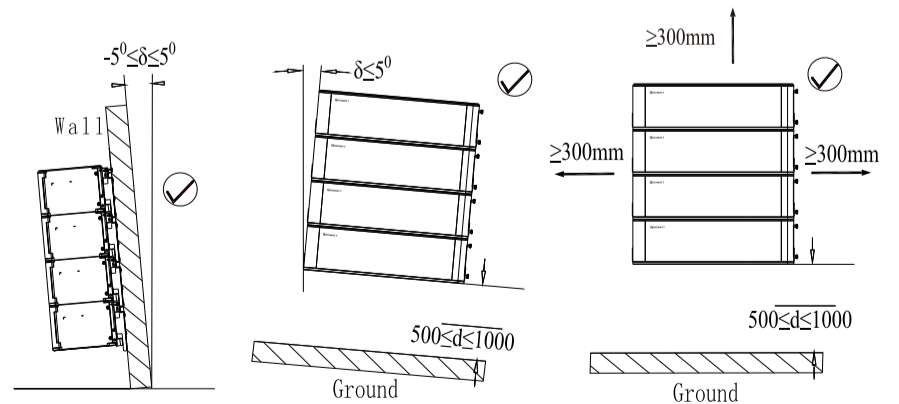

Note: The number of wall-mount installations should not exceed four. Please make sure that the weight capacity of wall should exceed 150kg.

3-2 Installation Procedure

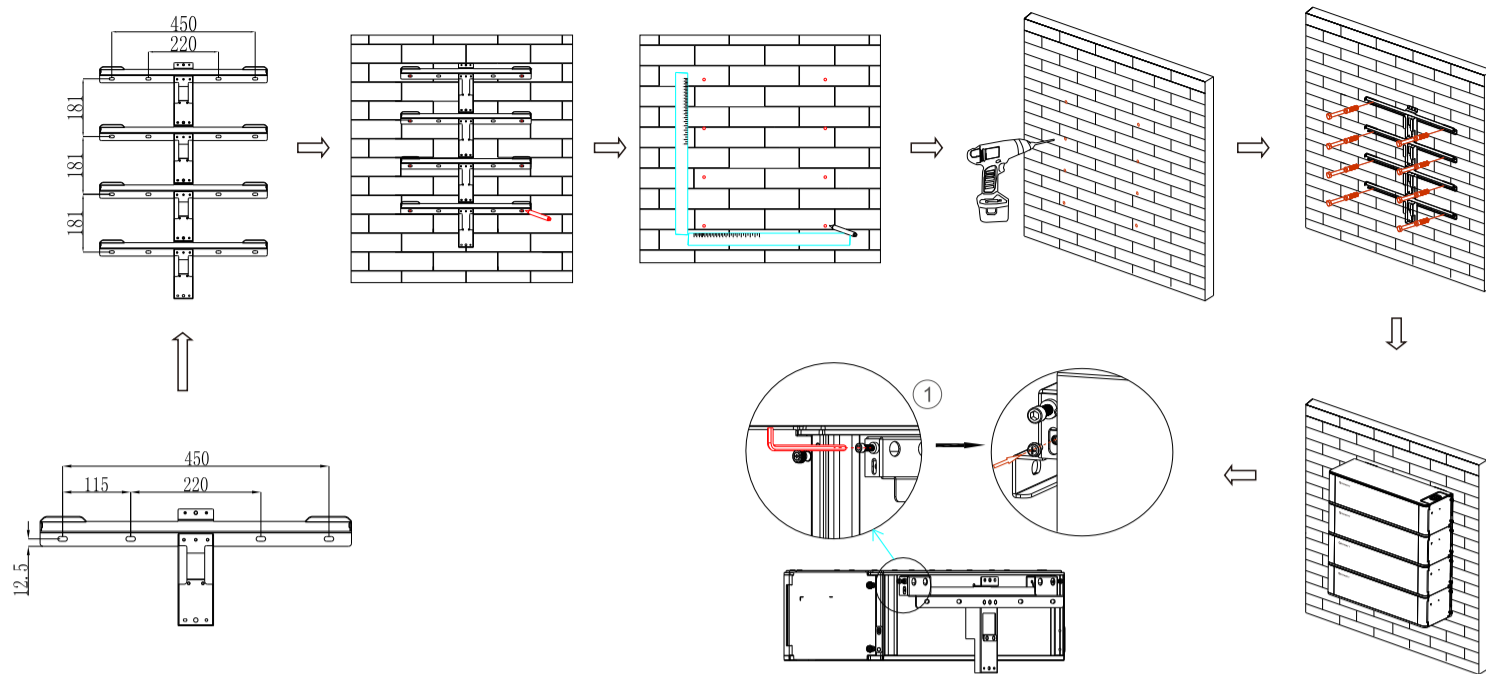

Note: Avoid drilling holes in the water pipes and cables buried in the wall.

① Adjust the screw to ensure the battery in horizontal position

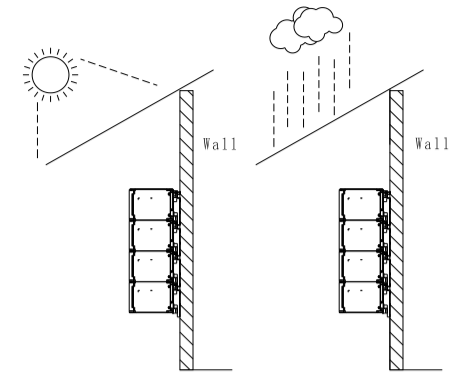

Note: Build sun& rain shade to avoid direct exposure to sunlight and rain.

5. Wire Connection

5-1 Connection end face introduction

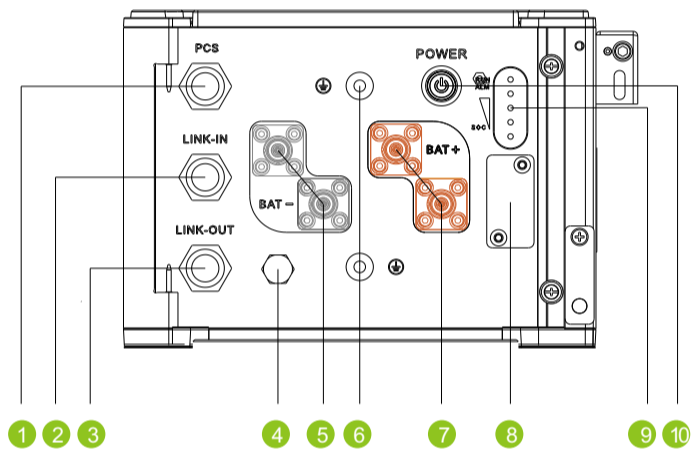

1	PCS CAN communication	6	GND terminal
2	LINK-IN CAN communication	7	Positive terminal
3	LINK-OUT CAN communication	8	USB interface
4	Safety vent	9	LED
5	Negative terminal	10	Power button

5-2 Diagram of wiring connection

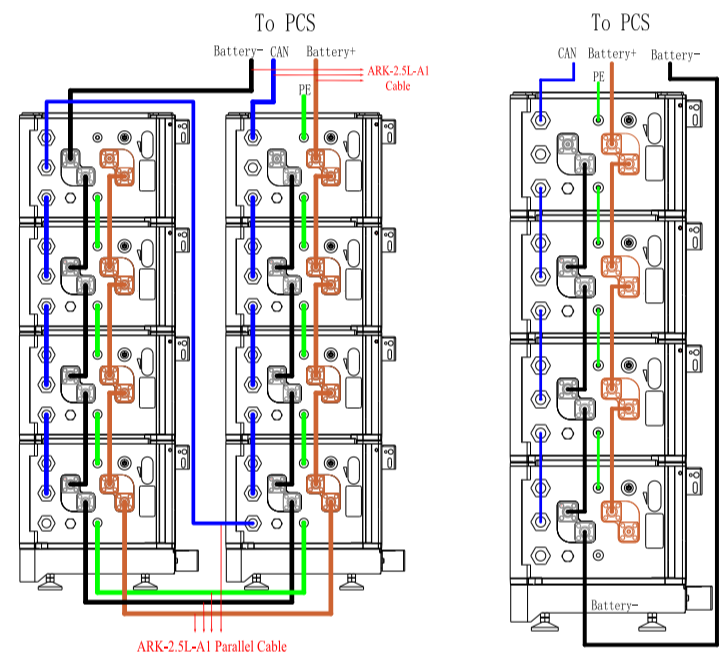

Note: The switch connect PCS to ARK-2.5L-A1, we recommend the use of molded case circuit breaker with rated working voltage greater than 80V and rated working current greater than 125A.

6. Terminal Connection

6-1 Power terminal

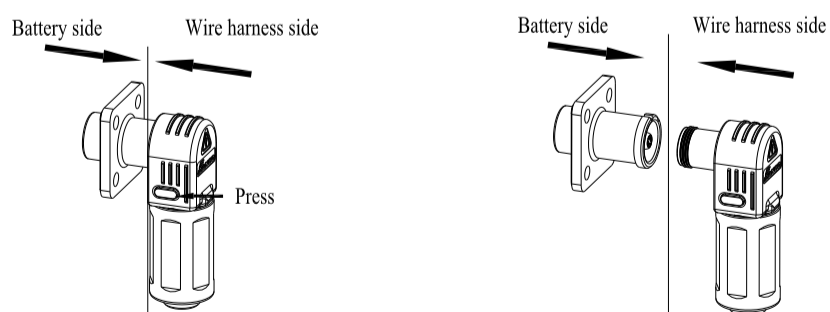

Press the position indicated in the figure above before disconnecting the power terminal.

6-2 Communication terminal

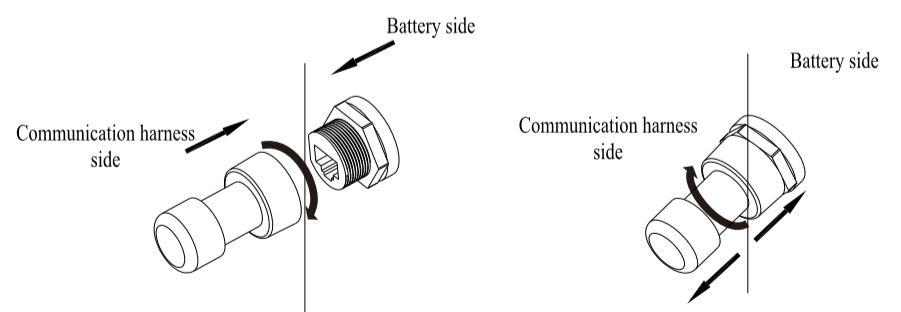

7. Key operation

Power Button

Situation	Touch	Definition	
System off	Press(< 2S)	No reaction	
	Press(≥2S)	Power on	
System on	Press once	Shut down	

Note: When multiple battery modules are used in parallel connection, you only need to press one key of any module to start the system, and also press one key to shut down the battery system. ALM/RUN light turns green when powered on

8. Service and contact

Shenzhen Growatt New Energy Co.,Ltd.
 4-13/F, Building A, Sino-German(Europe) Industrial Park,
 Hangcheng Ave, Bao'an District, Shenzhen, China
 ☎ 86 0755 2747 1942 ✉ service@ginverter.com
 W:www.ginverter.com



Growatt New Energy