





Future-H Series Energy Storage System User Manual





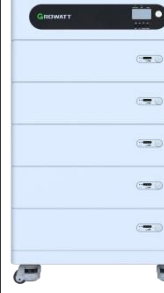

Introduction

System Introduction

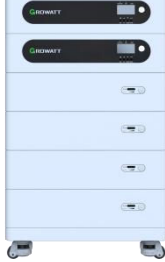
Growatt ALL-IN-ONE system including Inverter(SIM 6000 ES Plus-H series),Lithium battery(ABM 5.5L-A1-H series) and Mounting Base(ABM Battery Base).The system supports inverters and batteries combined freely, it can stand a maximum load of 400Kg, so we recommend the following combinations.

System combinations					
Rated Output Power	6KVA/6KW				
Battery count	2	3	4	5	6
Battery Energy	11KWH	16.5KWH	22KWH	27.5KWH	33KWH

System combinations					
Rated Output Power	12KVA/12KW			18KVA/18KW 1phase	18KVA/18KW 3 phase
Battery count	4	5	6	6	6
Battery Energy	22KWH	27.5KWH	33KWH	33KWH	33KWH

Scope

The manual solely covers the installation and assembly of the ALL-IN-ONE system, excluding operational instructions for inverters and lithium batteries. Therefore, prior to installing and assembling the entire system, it is recommended that you thoroughly review the user manuals for both inverters and lithium batteries.

Target Group

This document is intended for qualified persons and end users. Tasks that do not require any particular qualification can also be performed by end users. Qualified persons must have the following skills:

- ▶ Knowledge of how an inverter works and is operated
- ▶ Training in how to deal with the dangers and risks associated with installing and using electrical devices and installations
- ▶ Training in the installation and commissioning of electrical devices and installations
- ▶ Knowledge of the applicable standards and directives
- ▶ Knowledge of and compliance with this document and all safety information

Safety Instructions



WARNING: This chapter contains important safety and operating instructions. Read and keep this manual for future reference.

1. Before using the unit, read all instructions and cautionary marking on the unit, the batteries and all appropriate sections of this manual. The company has the right not to quality assurance, if not according to the instructions of this manual for installation and cause equipment damage.
2. All the operation and connection please professional electrical or mechanical engineer.
3. All the electrical installation must comply with the local electrical safety standards.
4. When install PV modules in the daytime, installer should cover the PV modules by opaque materials, otherwise it will be dangerous as high terminal voltage of modules in the sunshine.
5. Do not disassemble the unit. Take it to a qualified service center when service or repair is required. Incorrect re-assembly may result in a risk of electric shock or fire.
6. To reduce risk of electric shock, disconnect all wires before attempting any maintenance or cleaning. Turning off the unit will not reduce this risk.
7. For optimum operation of this inverter, please follow required spec to select appropriate cable size. It's very important to correctly operate this inverter.
8. Be very cautious when working with metal tools on or around batteries. A potential risk exists to drop a tool to spark or short circuit batteries or other electrical parts and could cause an explosion.
9. Please strictly follow installation procedure when you want to disconnect AC or DC terminals. Please refer to INSTALLATION section of this manual for the details.
10. GROUNDING INSTRUCTIONS -This inverter should be connected to a permanent grounded wiring system. Be sure to comply with local requirements and regulation to install this inverter.
11. **NEVER** cause AC output and DC input short circuited. Do NOT connect to the mains when DC input short circuits.
12. Make sure the inverter is completely assembled, before the operation.

Installation

Unpacking and Inspection

Before opening outer package, check if there is any visible damage on the outer package, such as holes, cracks or other signs of possible internal damage.

If there is any abnormality on the package or model of the energy storage is inconsistent, do not open it and contact your distributor.

Check the following parts list to ensure it is complete:

Part List			
Item	Item Name	Qty	Location
1	Communication cable	1	Inverter package box
2	Current sharing cable	1	Inverter package box
3	Parallel communication cable	1	Inverter package box
4	MC4 connector	4	Inverter package box
5	User manual	1	Inverter package box
6	Copper connector	2	Inverter package box
7	Tubular terminal	8	Inverter package box
8	R-type terminal	1	Inverter package box
9	AC input/output connector	2	Inverter package box
10	Copper connector	2	Battery package box
11	Communication cable	1	Battery package box
12	Shorting cap	1	Battery package box
13	Fixing plate & screws	2	Every package box

Note: The Software CD is no longer provided, if necessary, please download it from the official website www.ginverter.com

Selection of Installation Location

Basic Requirements

- When the energy storage is running, the temperature of the case and the radiator will be high. Therefore, do not install them in a place that is easy to touch.
- Do not install in areas where flammable and explosive materials are stored.
- If the energy storage is installed in areas with salt damage, it will be corroded and may cause fire. Therefore, do not install it outdoors in areas with salt damage. The areas with salt damage are defined as the areas which are not 500m away from shore or will be affected by sea breezes. The areas affected by the sea breezes vary depending on meteorological conditions (e.g. typhoons, monsoons) or topographical conditions (dams, hills).
- Do not install in the place where children can touch.
- When handling any heavy objects, you should be prepared to bear loads to avoid being crushed or sprained.
- When handling the device by hand, wear protective gloves to avoid injury

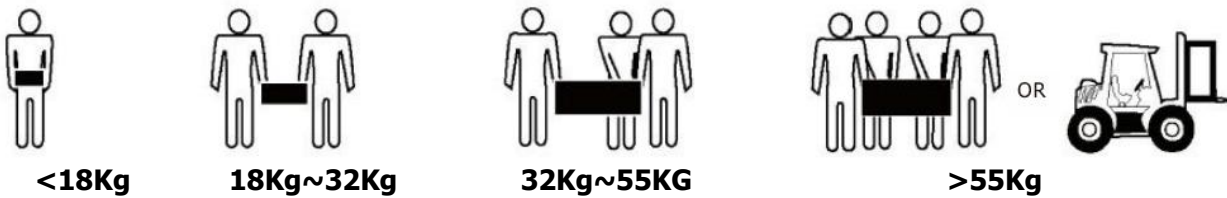

Installation Space Requirements

When installing the energy storage, certain space shall be left around it to ensure sufficient space for installation and heat dissipation.

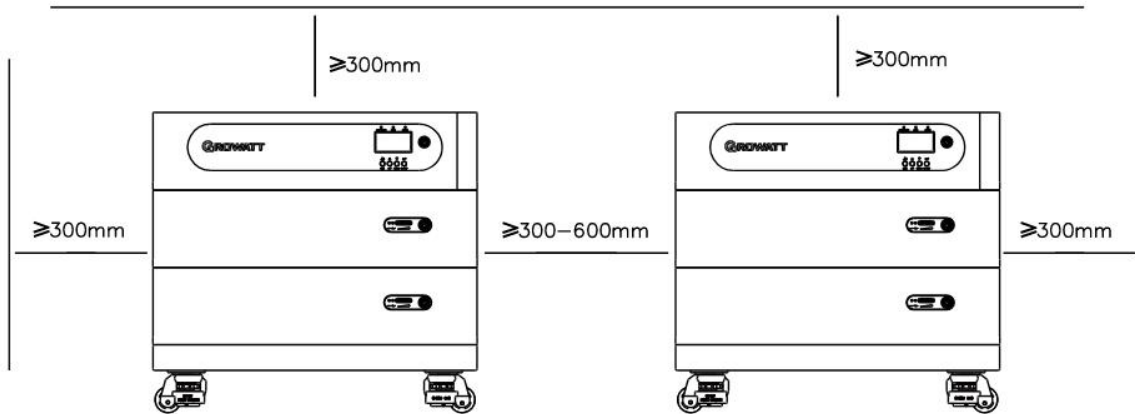

System Installation

The battery should be placed in the right position first, and the installation site should be smooth and the floor should be solid, and the device is $>10\text{cm}$ away from the wall.

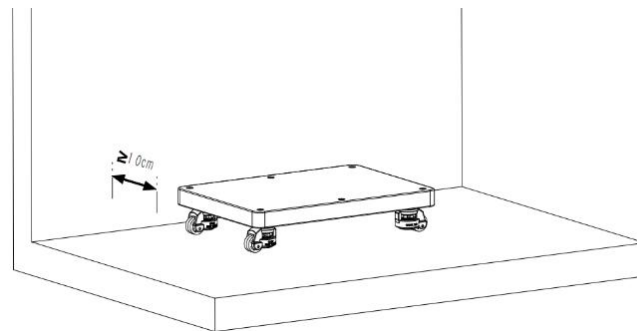

If there is more than one battery, the first battery should be placed properly before placing other batteries.

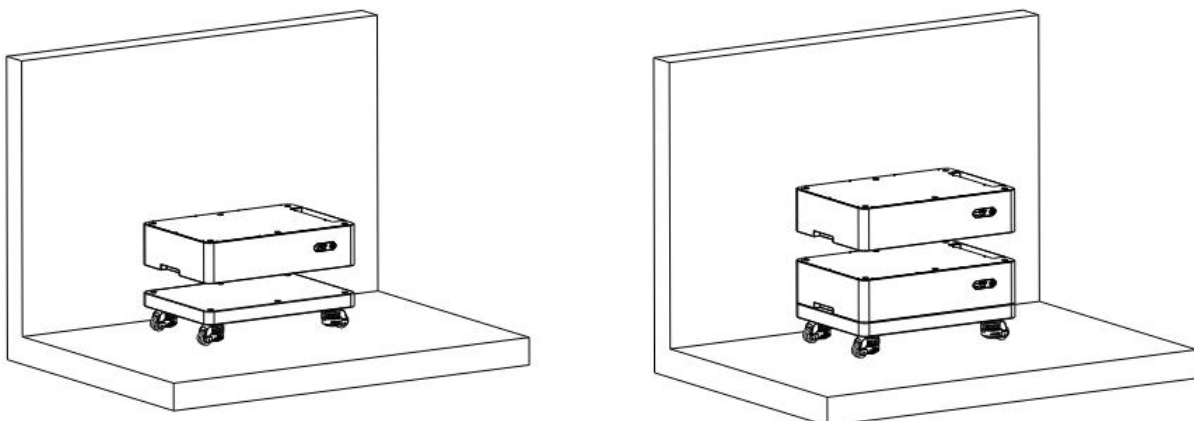

Installers should pay attention to the direction during installation. They shall be installed vertically and shall not be tilted.

You can install fixing plate to more stable as the picture below if you request or move.

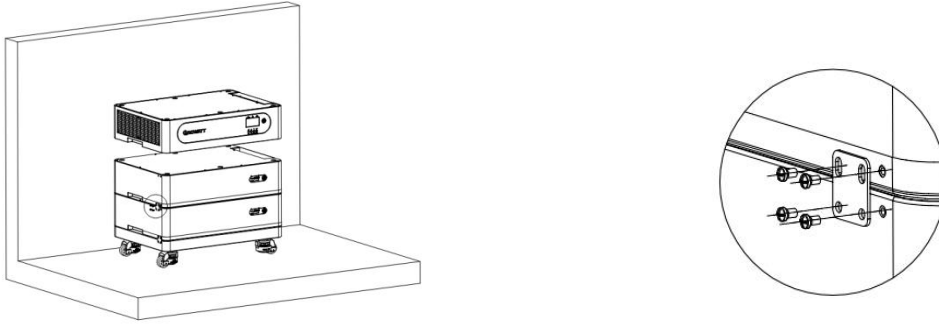

Install the PCS module, The PCS module should be installed at the top, not in other positions.

Electrical Connection

1.Ensure the battery is turned off. You are advised to use a meter to check.

2.Connecting Grounding Wire

a. Lock the Copper connector with the M6 screw as the table and picture below(There are red and black copper connectors):

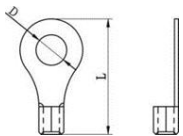
Part	Wire Gauge	Torque Value
	10AWG*20cm	1.2-1.6 Nm

b. Each battery module and inverter must be connected the grounding wire;

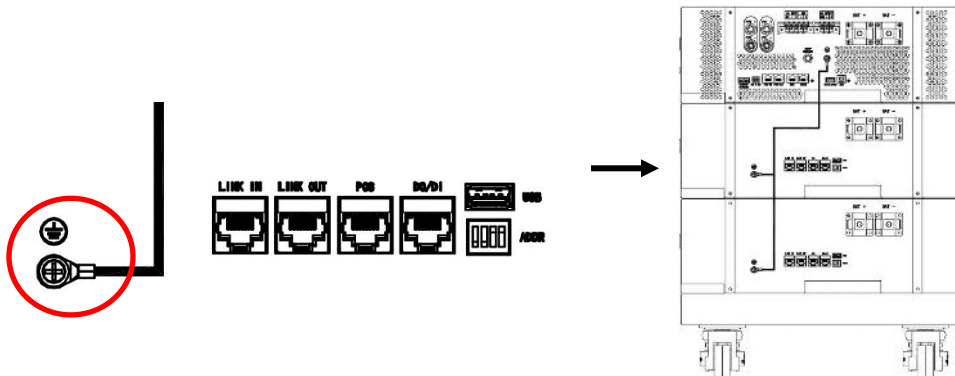

3.Connecting Power copper connector

Use the Copper connector with the M6 screw locking(the lock torque value:2-3Nm), as the table and picture below (There are red and black copper connectors)

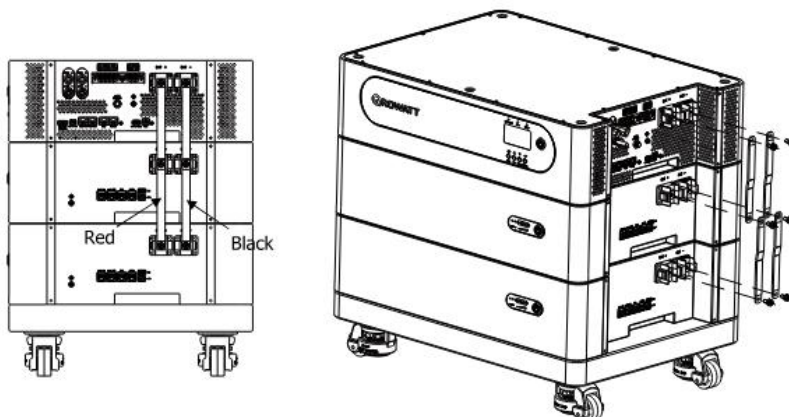

⚠ WARNING: The current capacity of power copper connector is 250A. If 3 inverters in parallel, it must connect other power cables.(Prepare by the user itself).
Recommended cable and ring terminal size as below.

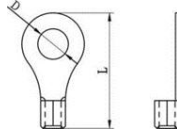

Wire size	Lenth	Ring Terminal		Torque value
		D(mm)	L(mm)	
2AWG	<530mm	6.4	39.2	2~3 Nm

If 3 inverters in parallel, it must connect other power cables

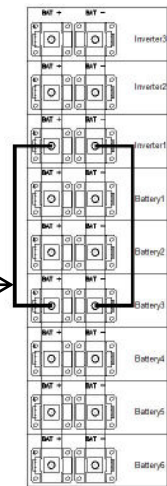

4.Connecting Communication cable

One inverter

Two inverters in parallel

Three inverters in parallel

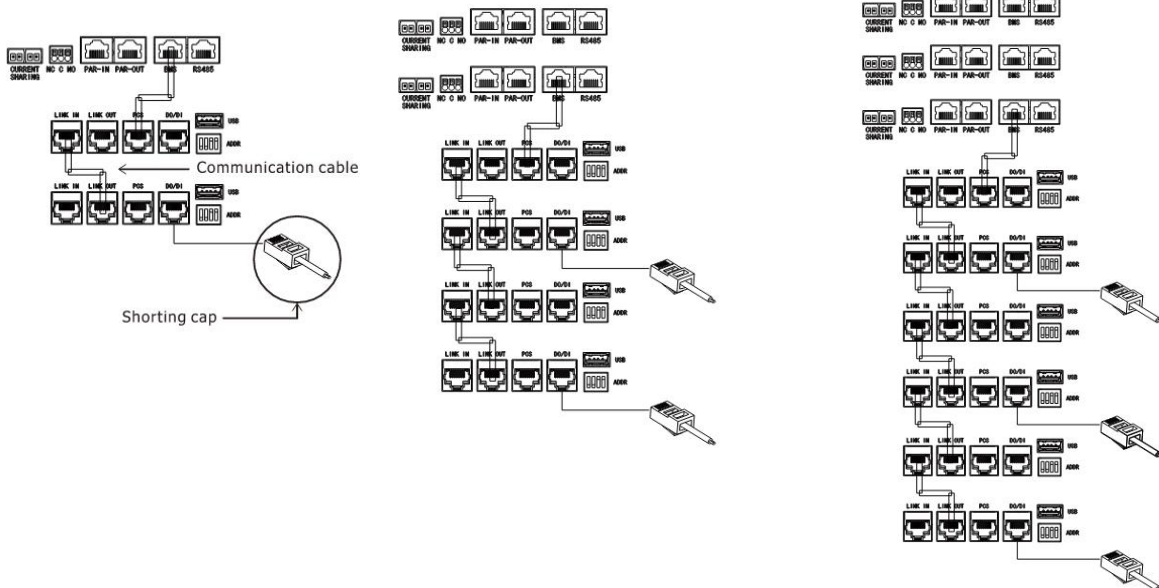

5.Lithium Battery Module Address Setting(Please refer to the ABM 5.5L-A1-H user manual)

6.External Electrical Connection of Energy Storage(Please refer to the SIM 6000 ES Plus-H user manual)

Power on/off

Power on:

1. Ensure all cables are connected correctly, Please check again;
2. Press the power button of any battery module($t > 1s$), The RUN/ALM and SOC lights turn on;
3. wait about 5s;
4. Press down the inverter ON/OFF button, The inverter will work.

Power off:

1. First, please turn off the electrical device at the load end of the inverter;
2. Press the inverter on/off button, turn off the inverter.
3. Press the power button of any battery module for 3 seconds and then release, the battery enters the shutdown state and all LED lights turn off.

System Maintenance

System Power-Off

1. After the system is powered off, the case still has residual power and heat, which may cause electric shocks or burns. Therefore, protective gloves should be worn before operating the energy storage 5 minutes later after system powered off. Maintenance operations on energy storage should be performed only after ensuring that all indicator lights of the energy storage are off;
2. When the system is running, the system cannot be powered off completely when only turning off the switch of the inverter. At this time, no maintenance operation can be performed on the system. The switch of battery must be turned off before maintenance operation can be performed;
3. Power-off operation steps of the system please see the previous chapter;

Routine Maintenance

To ensure the long-term and good operation of the energy storage system, it is recommended to perform the routine maintenance as described in this section

Items	Methods	Maintenance interval
System cleanliness for inverter	<ul style="list-style-type: none">● Clean the dust on the dust sponge	Once every 3 months.
Electrical connection	<ul style="list-style-type: none">● Check if any cable connection is off or loose.● Check if any cable is damaged, and especially if there are cuts on the sheath where the cable contacts with the metal surface.	Half a year after first debugging and testing, and once every six months to one year thereafter.
Grounding reliability	Check if the grounding cable is grounded reliably	Half a year after first debugging and testing, and once every six months to one year thereafter

Trouble Shooting(Please refer to the SIM 6000 ES Plus-H user manual or ABM 5.5L-A1-H user manual)