

1. Overview

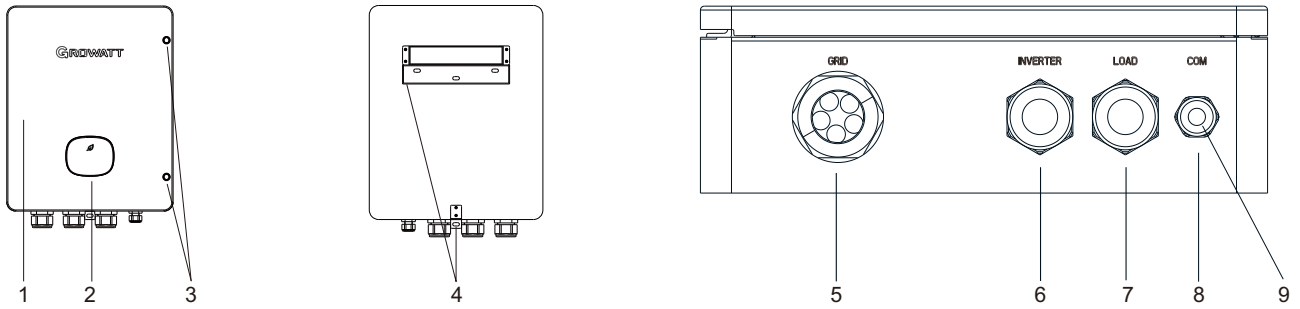

- (1) Front panel (2) LED indicator (3) Screw for front panel (4) Mounting bracket (5) Grid wiring port
- (6) Inverter wiring port (7) Load wiring port (8) COM wiring port (9) Waterproof plugs

2. Installation

System overview

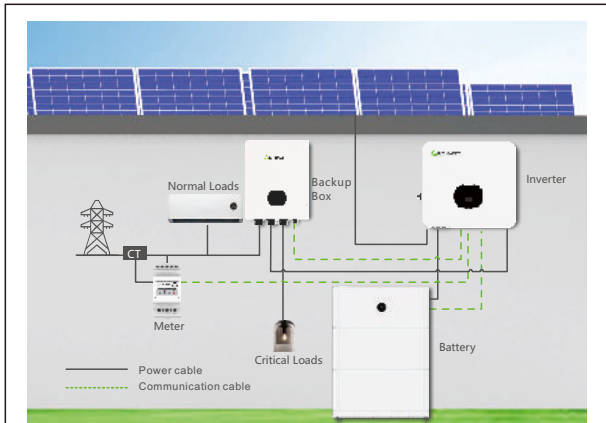

⚠ Note:

1. The critical load power depends on the power rating of the inverter and battery.
2. The off-grid function is only available when the XH inverter is paired with the APX battery system and the backup box.

2.2 Installation requirements

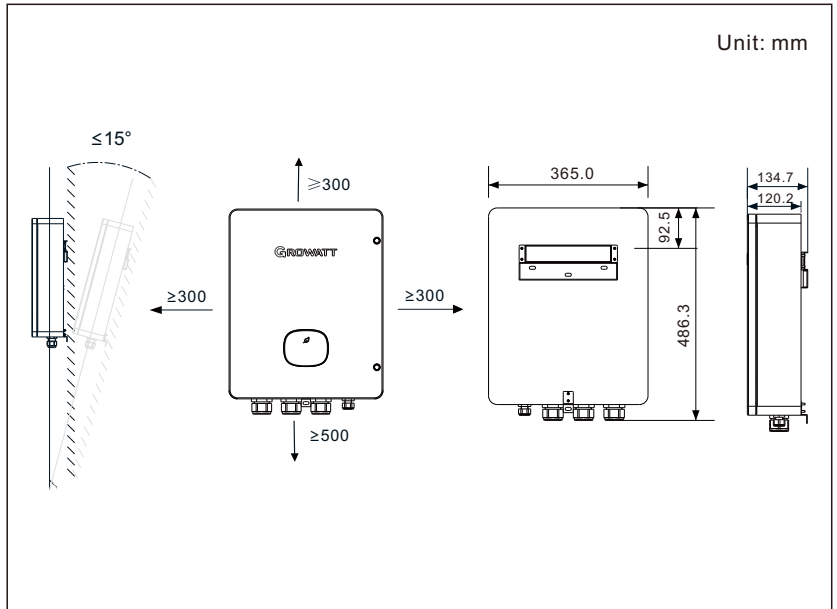

2.1 Electrical parameters

Model name	SYN 100-XH-30
Nominal grid voltage	3W/N/PE 230/400 a.c.V
Range of grid voltage	312 ~ 485 a.c.V
Max. grid current	125 a.c.A
Max. continuous grid current	90 a.c.A
Nominal grid frequency	50/60Hz
Range of grid frequency	45 ~ 65Hz
Max. continuous inverter input current	58 a.c.A
Max. backup output current	58 a.c.A

2.3 Installation steps

1. Choose a suitable installation position. The SYN 100-XH-30 can be mounted on a solid wall, a stud frame or a pole and keep it free from direct sunlight.
2. To ensure heat dissipation, please maintain at least a 300 mm clearance between the SYN 100-XH-30 and other objects.
3. Place the mounting bracket against the wall/pole and mark the drilling hole positions.
4. Drill holes and mount the bracket. Ensure that the bracket is securely installed.
5. Install the SYN 100-XH-30 onto the mounting bracket.

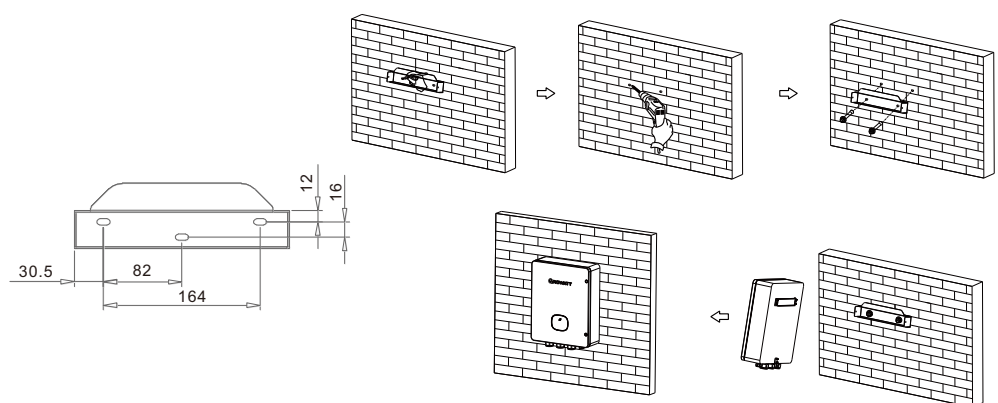

Dimensions (Unit: mm)

2.4 Required tools

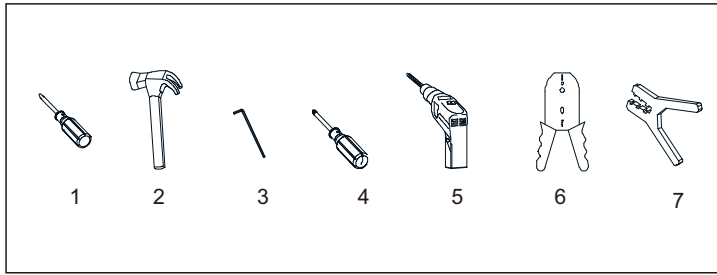

No.	Name	Size	No.	Name	Size
1	Flat-blade screwdriver	Φ2&5 mm	2	Hammer	/
3	Allen wrench	Φ5 mm	4	Phillips screwdriver	Φ5 mm
5	Electric drill	Φ6 mm	6	Wire stripper	/
7	Pliers	/			

3. Recommended cable specifications

Please prepare suitable cables for the connection of the SYN box following the recommended specifications, and the stripped length of the cables is 10 mm.

Cable	Cable outer diameter	Cable length
Grid input cable	4-6 AWG	10 m
Inverter input cable	6-8 AWG	20 m
Load output cable	6-8 AWG	20 m
Communication cable	22-26 AWG	20 m

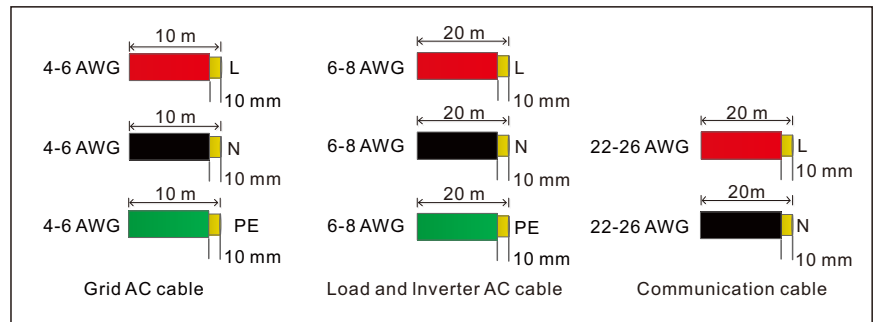

3.1 Wiring instructions

3.1.1 Connecting SYN 100-XH-30 to the Grid

1. Remove the two screws on the upper cover of the SYN 100-XH-30 to open the upper cover, and do not remove the cover inside the machine.
2. Twist the plastic cover printed with "Grid" counterclockwise, remove the five waterproof plugs, and reserve five holes.
3. Route the five power grid cables (L1/L2/L3/N/PE) through the five holes and connect them to the power grid input terminals and the ground copper bar. Screw torques for tightening the power grid terminals and ground terminals are shown in the following table.
4. Finally, fasten the plastic cover clockwise. The wiring method is shown in Figure 3.

	Screw torque
Power grid terminals	26.5 to 31 in*lbs
Ground terminal	13 in*lbs

Note: PE cables need to be crimped with the O-type terminal in the accessory bag, as shown in Figure 2.

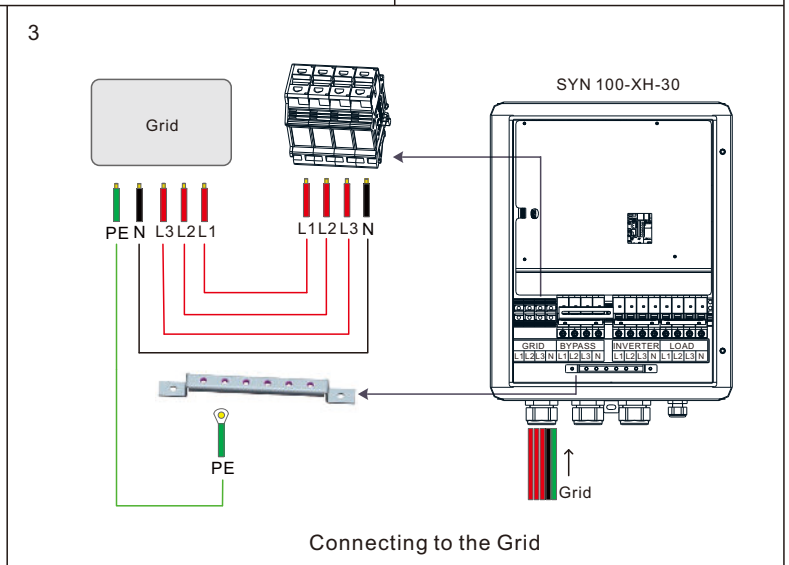
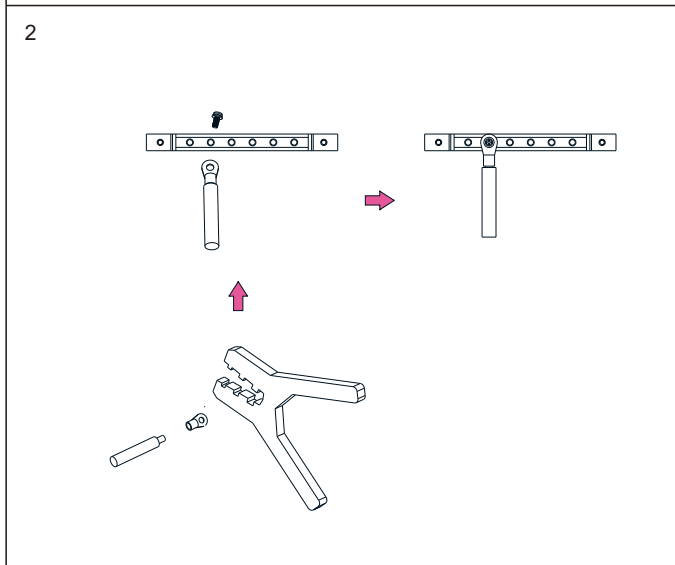

3.1.2 Connecting SYN 100-XH-30 to the Inverter

When connecting the SYN 100-XH-30 to the XH Inverter, you need to connect the AC power cables and the communication cables.

3.1.2.1 AC power cable connection:

1. Twist the plastic cover printed with "Inverter" counterclockwise; remove the five waterproof plugs, and reserve five holes.
2. Route the five cables of the inverter (L1/L2/L3/N/PE) through the five holes, connect the cables to the inverter breaker terminals (L1/L2/L3/N) and the ground copper bar. Screw torques for tightening the inverter breaker terminals and ground terminals are shown in the following table.
3. Finally, fasten the plastic cover clockwise. The wiring method is shown below:

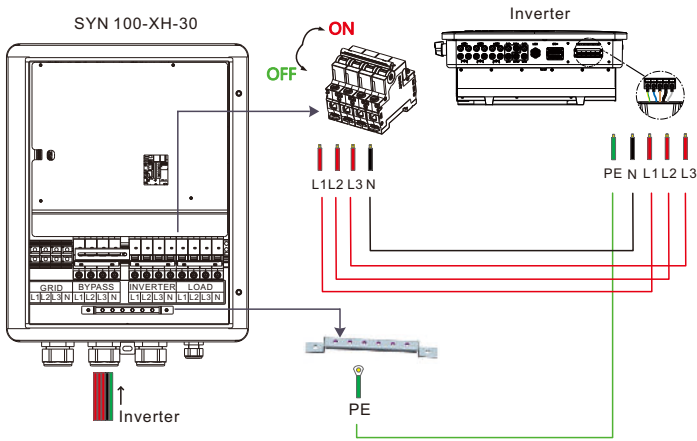

Connecting the AC cables to the XH Inverter

	Screw torque
Inverter circuit breaker terminals	17.5 in*lbs
Ground terminal	13 in*lbs

3.1.2.2 Communication cable connection:

1. Twist the plastic cover printed with "COM" on the machine counterclockwise; remove the waterproof plug, and reserve the hole.
2. Route the two communication cables (A/B) (the twisted pair cables are recommended) and the two BOX EN cables (EN+/EN-) through the hole, connect them to the CN8 terminals on the control board. Connect the other end of the cables to the COM terminals of the inverter, and tighten the screws. The following table lists the corresponding terminal pins. The wiring method is shown as follows:

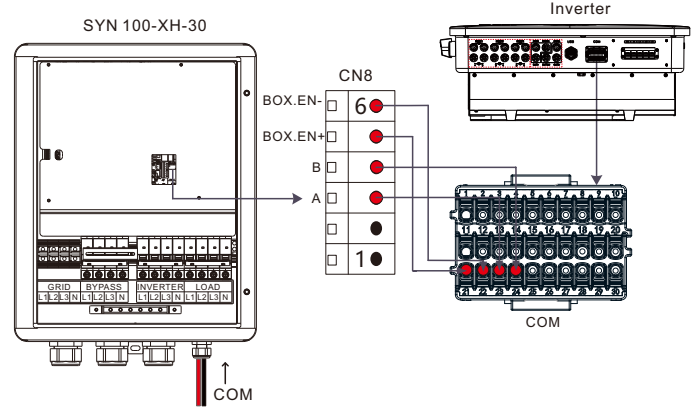

Connecting the communication cables to the XH Inverter

COM Port	XH Inverter COM	SYN 100-XH-30 COM	Control Board
RS485 A	PIN 23	PIN 3	CN8
RS485 B	PIN 24	PIN 4	
BOX.EN+	PIN 21	PIN 5	
BOX.EN-	PIN 22	PIN 6	

3.1.3 Connecting SYN 100-XH-30 to the load

1. Twist the plastic cover printed with "Load" counterclockwise, remove the five waterproof plugs, and reserve five holes.
2. Route the five load cables (L1/L2/L3/N/PE) through the five holes, connect them to the load circuit breaker terminals (L1/L2/L3/N) and the ground copper bar. Screw torques for tightening the load breaker terminals and ground terminals are shown in the following table.
3. Finally, fasten the plastic cover clockwise. The wiring method is shown to the right:

	Screw torque
Load breaker terminal	17.5 in*lbs
Ground terminal	13 in*lbs

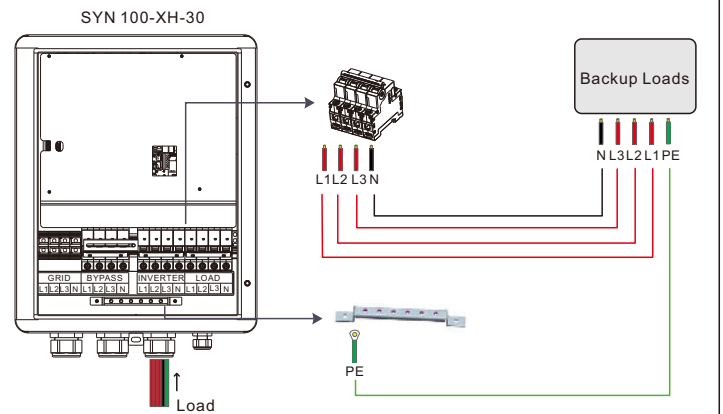

Connecting to the AC Loads

4. Indicator description

System state	Indicator status	
	Green	Red
On-grid Mode	On	Off
Back-up Mode	Blinking (On for 1s, and then Off for 1s)	Off
No communication with the inverter	Off	Blinking (on for 1s, and then Off for 1s)
System fault	Off	On
Firmware upgrade	When the upgrade starts, the yellow light is on or off for 10-20s, and then the yellow light blinks at intervals of 2s (On for 1s and then Off for 1s).	

5. System startup and shutdown operations

5.1 To start the system, please perform the following steps:

1. If the inverter is connected to a battery, turn the DC SWITCH on the battery to ON.
2. Set the DC SWITCH on the left side of the inverter to ON.
3. Turn on the inverter input breaker of the SYN 100-XH-30.
4. Enable the Backup Box function via inverter settings. For details, please refer to the XH inverter manual.
5. Turn on the grid breaker.
6. If the SYN 100-XH-30 indicator light turns green after completing the preceding steps, it indicates that the SYN 100-XH-30 is functioning properly.
7. If you cannot power on the system with the instructions provided above, please contact Growatt.

5.2 To shut down the system, please perform the following steps:

1. Disconnect the Inverter input breaker and the load input breaker on the SYN 100-XH-30 and then disconnect the power grid breaker.
2. Turn off the DC switch of the inverter.
3. Turn off the DC switch of the battery.
4. Wait for a while and all the indicators of the inverter, the battery, and the SYN 100-XH-30 will go off, indicating that the system is powered off completely.

6. Transfer to the bypass mode manually

When the SYN 100-XH-30 fails, it cannot transfer to the bypass mode automatically. To ensure uninterrupted power supply to loads, it can be switched to the bypass mode manually.

To manually transfer to the bypass mode, please proceed as follows:

1. Shut down the entire system. For details, please refer to Section 5.2.
2. Use a Phillips screwdriver to loosen the limit switch screw on the power bypass switch.
3. Slide the firmware to one end of the inverter switch.
4. Tighten the screw on the limit switch with a torque of 10.5 in* lbs / 1.2 N*m. Turn on the power bypass switch. The operation instructions are shown below.
5. Power on the entire system. For details, please refer to section 5.1.

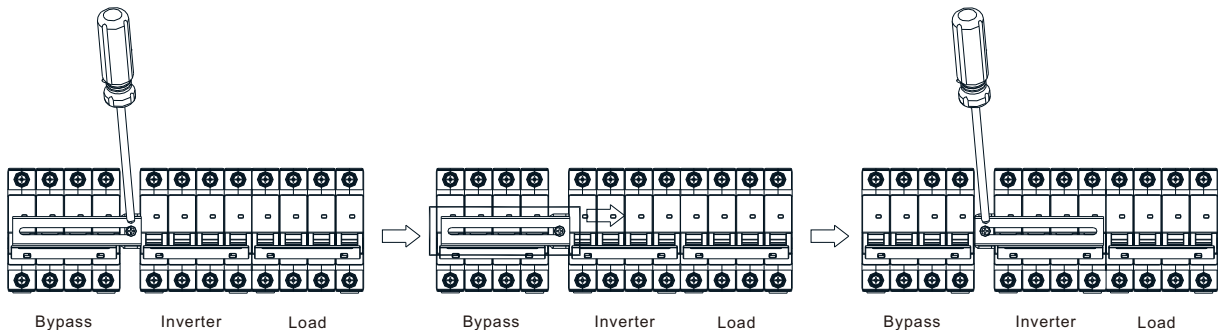

7. Service and contact

Shenzhen Growatt New Energy Co., Ltd.
4-13/F, Building A, Sino-German (Europe) Industrial Park,
Hangcheng Ave, Bao'an District, Shenzhen, China

T +86 755 2747 1942

E service@ginverter.com

W www.ginverter.com



Download
Manual



Growatt New Energy

GR-UM-312-A-01